

ETERNITY IN STONE

Product order form

Please call our studios prior to faxing your completed order forms.
(905) 494-1774 or toll free 1 (866) 494-1774

A. Funeral Home Information

Company _____ Contact _____
E-Mail address _____ Fax _____
Phone _____ Date _____

B. Billing and Shipping information

Name _____ Company _____
Address _____
City _____ Province _____ Postal code _____

Item Description	Item #	Quantity	Total

Special Instructions _____

Name of deceased _____

Date of Birth _____ Date of Passing _____

Our business account terms are net 30 days. If paying by Visa please contact our office for instructions.

Remember

To ensure a proper fit we recommend you measure the interior casket lid opening in inches. Then fill in the dimensions in the boxes provided. We also include panel mounting pins with every panel purchased.

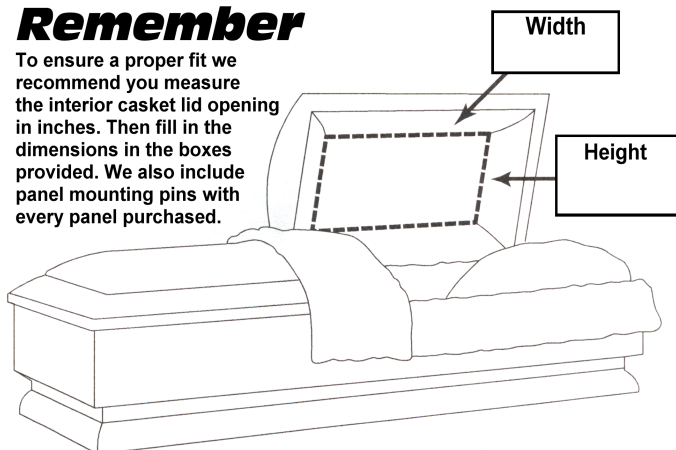

Shipping/Handling	+ _
Subtotal	
G.S.T.	+
P.S.T.	+
Grand Total	=